

COURSE OVERVIEW EE0347

Interpreting and Following Electrical Engineering Documentation

Course Title

Interpreting and Following Electrical Engineering Documentation

Course Date/Venue

Session 1: February 24-28, 2025/Fujairah Meeting Room, Grand Millennium Al Wahda Hotel, Abu Dhabi, UAE
 Session 2: September 21-25, 2025/Boardroom 1, Elite Byblos Hotel Al Barsha, Sheikh Zayed Road, Dubai, UAE

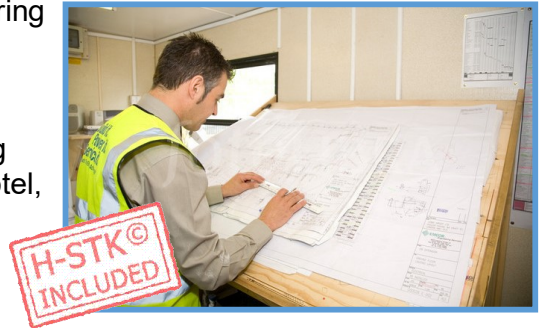

Course Reference
EE0347



Course Duration/Credits

Five days/3.0 CEUs/30 PDHs

Course Description

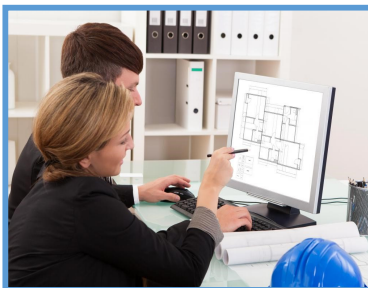

This practical and highly-interactive course includes various practical sessions and exercises. Theory learnt will be applied using our state-of-the-art simulators.

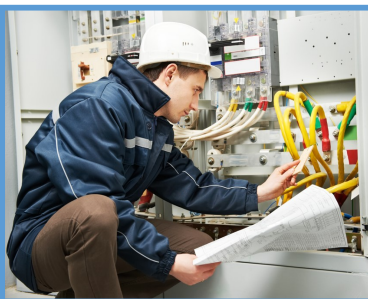

This course is designed to provide participants with an advanced and specialized interpretation of electrical drawings. It covers the engineering drawings and piping and instruments drawings (P&IDs); the electrical drawings, schematics and elementary electrical diagrams; the various types of electrical drawings; reading simple drawings and SLD; the SLD diagram sketching and components of electrical circuitry using SLD; the interpretation and usage of electrical schematics and electrical symbols standard; and the DC voltage schematic, AC voltage schematic, one-line diagrams and 2-3 wire control circuits.



Further, the course will discuss the sealing circuits, forward-reverse circuits, timing circuits and NEMA and IEC circuit; the equipment identification and inventory; the nomenclature verification, block diagram preparation, interconnecting the equipment and supervising connection using SLD; the electrical components/protections and control circuits; the electrical drawings reading; the PLC ladder logic, relay/ladder logic diagrams, logic symbols and electrical circuit logic; the power circuits and control circuits; and the accurate wiring of circuits and connections.

During this interactive course, participants will learn the three-phase motor control, power circuits and control circuits troubleshooting; creating and maintaining regulatory compliant electrical diagrams; the electrical drawings for troubleshooting and diagnostics; the effective troubleshooting approach, evaluating and assessing the fault and mapping a solution; the task, hazards, electronic diagrams and schematics and engineering logic diagrams; and the engineering fabrication, construction and architectural drawings and CAD applications.

Course Objectives

Upon the successful completion of this course, each participant will be able to:-

- Apply and gain an advanced and specialized knowledge on the interpretation of electrical drawings
- Read and interpret drawings and schematics
- Identify electrical components and relate drawings to real world applications
- Use drawings and schematics for troubleshooting and communicate with others as well as create own drawings
- Discuss engineering drawings and piping and instruments drawings (P&IDS)
- Illustrate electrical drawings and schematics and elementary electrical diagrams
- Identify the various types of electrical drawings and read simple drawings and SLD
- Sketch SLD diagram and discuss the components of electrical circuitry using SLD
- Interpret and use electrical schematics as well as recognize electrical symbols standard
- Determine DC voltage schematic, AC voltage schematic, one-line diagrams and 2-3 wire control circuits
- Differentiate sealing circuits, forward-reverse circuits, timing circuits and NEMA and IEC circuit
- Carryout equipment identification and inventory, nomenclature verification, block diagram preparation, interconnecting the equipment and supervising connection using SLD
- Identify electrical components/protections and control circuits
- Read electrical drawings and illustrate PLC ladder logic, relay/ladder logic diagrams, logic symbols and electrical circuit logic
- Recognize power circuits and control circuits as well as carryout accurate wiring of circuits and connections
- Identify three-phase motor control and power circuits and troubleshoot control circuits
- Verify electrical prints and make changes to existing diagrams
- Create and maintain regulatory compliant electrical diagrams as well as apply electrical drawings for troubleshooting and diagnostics
- Employ effective troubleshooting approach, evaluate and assess the fault and map a solution
- Identify task, hazards, electronic diagrams and schematics and engineering logic diagrams
- Carryout engineering fabrication, construction and architectural drawings and CAD applications

Exclusive Smart Training Kit - H-STK®



Participants of this course will receive the exclusive “Haward Smart Training Kit” (H-STK®). The H-STK® consists of a comprehensive set of technical content which includes **electronic version** of the course materials conveniently saved in a **Tablet PC**.

Who Should Attend

This course provides an advanced and specialized interpretation of electrical drawings for electrical engineers, project managers, inspectors, contractors, supervisors, foremen, draftsmen and other technical staff.

Training Methodology

All our Courses are including **Hands-on Practical Sessions** using equipment, State-of-the-Art Simulators, Drawings, Case Studies, Videos and Exercises. The courses include the following training methodologies as a percentage of the total tuition hours:-

- 30% Lectures
- 20% Practical Workshops & Work Presentations
- 30% Hands-on Practical Exercises & Case Studies
- 20% Simulators (Hardware & Software) & Videos

In an unlikely event, the course instructor may modify the above training methodology before or during the course for technical reasons.

Accommodation

Accommodation is not included in the course fees. However, any accommodation required can be arranged at the time of booking.

Course Fee

US\$ 5,500 per Delegate + **VAT**. This rate includes H-STK® (Haward Smart Training Kit), buffet lunch, coffee/tea on arrival, morning & afternoon of each day.

Course Certificate(s)

Internationally recognized certificates will be issued to all participants of the course who completed a minimum of 80% of the total tuition hours.

Certificate Accreditations

Certificates are accredited by the following international accreditation organizations: -

- 
British Accreditation Council (BAC)

Haward Technology is accredited by the **British Accreditation Council** for **Independent Further and Higher Education** as an **International Centre**. BAC is the British accrediting body responsible for setting standards within independent further and higher education sector in the UK and overseas. As a BAC-accredited international centre, Haward Technology meets all of the international higher education criteria and standards set by BAC.

- 
The International Accreditors for Continuing Education and Training (IACET - USA)

Haward Technology is an Authorized Training Provider by the International Accreditors for Continuing Education and Training (IACET), 2201 Cooperative Way, Suite 600, Herndon, VA 20171, USA. In obtaining this authority, Haward Technology has demonstrated that it complies with the **ANSI/IACET 2018-1 Standard** which is widely recognized as the standard of good practice internationally. As a result of our Authorized Provider membership status, Haward Technology is authorized to offer IACET CEUs for its programs that qualify under the **ANSI/IACET 2018-1 Standard**.

Haward Technology's courses meet the professional certification and continuing education requirements for participants seeking **Continuing Education Units (CEUs)** in accordance with the rules & regulations of the International Accreditors for Continuing Education & Training (IACET). IACET is an international authority that evaluates programs according to strict, research-based criteria and guidelines. The CEU is an internationally accepted uniform unit of measurement in qualified courses of continuing education.

Haward Technology Middle East will award **3.0 CEUs** (Continuing Education Units) or **30 PDHs** (Professional Development Hours) for participants who completed the total tuition hours of this program. One CEU is equivalent to ten Professional Development Hours (PDHs) or ten contact hours of the participation in and completion of Haward Technology programs. A permanent record of a participant's involvement and awarding of CEU will be maintained by Haward Technology. Haward Technology will provide a copy of the participant's CEU and PDH Transcript of Records upon request.

Course Instructor(s)

This course will be conducted by the following instructor(s). However, we have the right to change the course instructor(s) prior to the course date and inform participants accordingly:



Mr. Sherif Bayoumi, BSc, is a **Senior Electrical Engineer** with over **40 years** of extensive experience within **Oil, Gas, Petrochemical** and **Power** industries. His expertise widely covers **Electrical Systematics Troubleshooting, Electrical Distribution Systems & Control Circuits, Electrical Parameters, Maintenance of Electrical Switchgear & Overhead Lines, Switchgear and Transformers, HV Switchgear Operation & Maintenance, Distribution Switchgear & Equipment, Symmetrical & Unsymmetrical Faults, Electrical Drawings, Relay Logic Circuits, Test Requirements, Component Testing Procedures, Electrical & Control System, Troubleshooting Transformers, Equipment Troubleshooting, System Grounding, Circuit Breakers, Protection Devices & Technology, Protection Relay, Solid State Relay, Instrument Transformers, Grading & Protection Coordination, Electrical System & Equipment, Generators, Gas Turbine, Diesel Generators, Power Transformers, AC & DC Motors, Substations, Switchgears & Distribution, Power System Analysis, Electrical Equipment Control Systems, Cables & Domestic Wiring, Overhead Transmission Lines, Electrical Safety, Electrical Protection, Batteries, Chargers & UPS, Electrical Projects Handling, Electrical Measurements, Medium Voltage Switchgears (MVSG), Motor Control Centers (MCC), Electrical Submersible Pumps (ESP)**. He is also well-versed in **Preventive Maintenance, Health, Safety & Environmental Management System (HSEMS), On-Shore & Off-Shore Electrical Installations, Engineering Studies, Water Desalination Units, Induction Motors, Power Supply Substations, Electro-mechanical Protection Relays, Engineering Drawings, Industrial Power System Coordination, Machinery Vibration, Dynamic Balancing Analysis, Material & Equipment Standard & Code System, Hazardous Area Classification, Safety Management System, Emergency Response, Permit to Work & Issuing Authority, Defensive Driving and Task Risk Assessment**.

During Mr. Sherif's career life, he has occupied various key positions in several companies such as the **Electrical Maintenance Engineer, Senior Electrical Support Engineer, Lead Maintenance Electrical Engineer, Maintenance Electrical Engineer, Specialist Electrical Engineer in Abu Dhabi Company for Onshore Oil Operations (ADCO), Gulf of Suez Petroleum Company (GUPCO) and West Desert Petroleum Company (WEPCO)**.

Mr. Sherif has a **Bachelor's** degree in **Electrical Power Engineering**. Further, he is a **Certified Instructor/Trainer** and has delivered numerous courses, trainings, workshops, seminars and conferences internationally.

Course Program

The following program is planned for this course. However, the course instructor(s) may modify this program before or during the course for technical reasons with no prior notice to participants. Nevertheless, the course objectives will always be met:

Day 1

0730 – 0800	<i>Registration & Coffee</i>
0800 – 0815	<i>Welcome & Introduction</i>
0815 – 0830	PRE-TEST
0830 – 0900	<i>Introduction to Engineering Drawings</i>
0900 – 0915	<i>Piping & Instruments Drawings (P & IDs)</i>
0915 – 0930	<i>Break</i>
0930 – 1000	<i>Electrical Diagrams & Schematics</i>
1000 – 1030	<i>Elementary Electrical Diagrams</i>
1030 – 1100	<i>Types of Electrical Drawings</i>
1100 – 1115	<i>Break</i>
1115 – 1130	<i>Reading Simple Drawings & SLD</i>
1130 – 1145	<i>Sketching SLD Diagram</i>
1145 – 1215	<i>Components of Electrical Circuitry Using SLD</i>
1215 – 1230	<i>Practical Exercise Using Schematics</i>
1230 – 1300	<i>Prayer time</i>
1300 – 1320	<i>Electrical Schematics Interpretation & Use</i>
1320 – 1330	Recap
1330	<i>End of Day One</i>

Day 2

0730 – 0800	<i>Electrical Symbols Standard & Identification</i>
0800 – 0830	DC Voltage Schematic
0830 – 0915	<i>Practical Exercise of Symbol Identification, Basic Information Location & Schematic Diagram Layout</i>
0915 – 0930	<i>Break</i>
0930 – 1030	AC Voltage Schematic Equipment Identification and Fault Finding
1030 – 1100	<i>Practical Exercise Using Elementary Diagrams (Identification of Circuits, and the Uses of Single Line, AC Schematic and Three Line Diagrams)</i>
1100 – 1115	<i>Break</i>
1115 – 1130	One-Line Diagrams
1130 – 1145	2 Wire Control Circuits
1145 – 1200	3 Wire Control Circuits
1200 – 1230	Sealing Circuits
1230 – 1300	<i>Prayer Time</i>
1300 – 1320	Forward-Reverse Circuits
1320 – 1330	Recap
1330	<i>End of Day Two</i>

Day 3

0730 - 0800	Timing Circuits
0800 - 0830	NEMA & IEC Circuit Comparison
0830 - 0915	Equipment Identification & Inventory
0915 - 0930	<i>Break</i>
0930 - 1000	Nomenclature Verification
1000 - 1030	Preparing a Block Diagram
1030 - 1100	Interconnecting the Equipment
1100 - 1115	<i>Break</i>
1115 - 1145	Supervising Connection Using SLD
1145 - 1215	Identify Electrical Components/Protections & Control Circuits
1215 - 1230	Reading Electrical Drawings
1230 - 1300	<i>Prayer Time</i>
1300 - 1320	PLC Ladder Logic
1320 - 1330	Recap
1330	<i>End of Day Three</i>

Day 4

0730 - 0800	Relay/Ladder Logic Diagrams
0800 - 0830	Logic Symbols
0830 - 0915	Electrical Circuit Logic
0915 - 0930	<i>Break</i>
0930 - 1000	Power Circuits & Control Circuits
1000 - 1030	Accurate Wiring of Circuits & Connections
1030 - 1100	Three-Phase Motor Control & Power Circuits
1100 - 1115	<i>Break</i>
1100 - 1130	Troubleshooting Control Circuits
1130 - 1200	Verifying Electrical Prints & Make Changes to Existing Diagrams
1200 - 1215	Creating & Maintaining Regulatory Compliant Electrical Diagrams
1230 - 1300	<i>Prayer Time</i>
1300 - 1320	Electrical Drawings for Troubleshooting & Diagnostics
1320 - 1330	Recap
1330	<i>End of Day Four</i>

Day 5

0730 - 0800	Effective Troubleshooting Approach
0800 - 0830	Evaluating & Assessing the Fault Mapping a Solution
0830 - 0915	Task Identification
0915 - 0930	<i>Break</i>
0930 - 1000	Identifying the Hazards
1000 - 1030	Practical Exercise Using Schematics of Different Electrical Circuits
1030 - 1100	Electronic Diagrams & Schematics
1100 - 1115	<i>Break</i>
1115 - 1130	Engineering Logic Diagrams
1130 - 1145	Engineering Fabrication, Construction & Architectural Drawings



1145 - 1200	CAD Applications
1200 - 1215	CAD Applications (cont'd)
1215 - 1245	<i>Prayer Time</i>
1245 - 1300	Course Conclusion
1300 - 1315	POST-TEST
1315 - 1330	<i>Presentation of Course Certificates</i>
1330	<i>End of Course</i>



Simulator (Hands-on Practical Sessions)

Practical sessions will be organized during the course for delegates to practice the theory learnt. Delegates will be provided with an opportunity to carryout various exercises using our state-of-the-art simulators “Troubleshooting Electrical Circuits V4.1” and the “AutoCAD”.

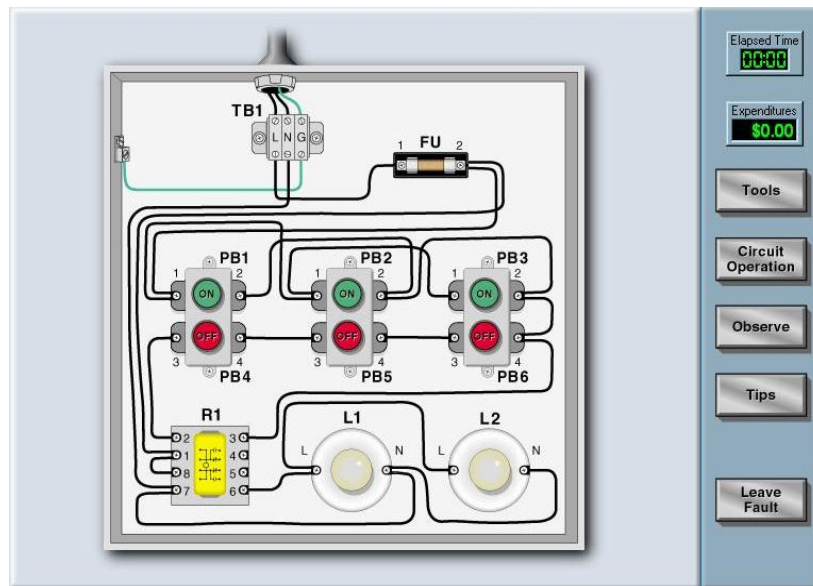

Basic Techniques

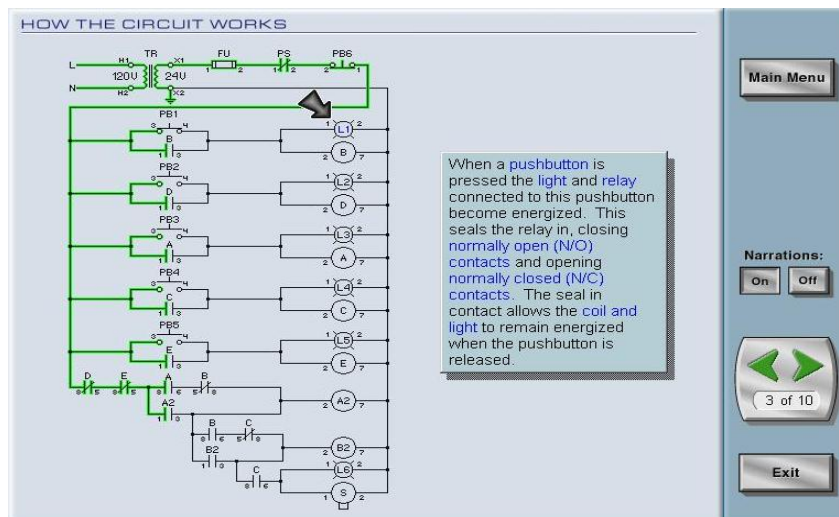

Basic Control Circuits



Motor Control Techniques

AutoCAD Software

Course Coordinator

Mari Nakintu, Tel: +971 2 30 91 714, Email: mari1@haward.org

